

Fall Final Report

Team 9

Power Converting Sub-System of Kite Power Generator

Members

Matt Hedine	mch13b
Zachary Ezzo	zre12
Andrew Colangelo	ajc13g
Denitsa Kurteva	dk13b

Faculty Advisor

Dr. Taira

Sponsor

Jeff Phipps

Instructor

Dr. Gupta & Dr. Shih

Date Submitted

12/5/2016

Table of Contents

Table of Figures.....	iv
Table of Tables.....	v
ABSTRACT.....	vi
ACKNOWLEDGMENTS	vii
1. Introduction.....	1
2. Project Definition.....	3
2.1 Needs Statement.....	3
2.2 Background Research	3
2.2.1 Kiteship.....	3
2.2.2 Skysails	3
2.2.3 Strandbeests.....	4
2.2.4 Kitano	5
2.3 Goal Statement/Objective	5
2.4 Constraints	6
3. Methodology	7
3.1 HOQ.....	7
3.2 Scheduling.....	8
3.3 Resource Allocation.....	8
4. Concept Generation.....	10
4.1 Concept Idea 1	10
4.2 Concept Idea 2	11
4.3 Concept Idea 3	12
4.4 Selection Matrix.....	13

4.5	Kite Stabilization Concepts.....	13
4.5.1	Kite Tails.....	13
4.5.2	Kite Rudder	14
4.5.3	Double Winch Stabilizer.....	15
4.5.4	Evaluation	16
4.6	Demonstration Concept	16
5.	Conclusion	18
	References.....	19

Table of Figures

Figure 1: Picture of Jeff Phipps Pogo Solenoid Patent	1
Figure 2: Flow chart of power generation for magnet through coil attached to a spring	2
Figure 3: Skysails used for towing boats so no electricity is used.....	4
Figure 4: Strandbeest creation that will walk across a beach using only wind power.....	5
Figure 5: HOQ to show initial customer requirements and engineering characteristics	7
Figure 6: Schedule for the remainder of the semester	8
Figure 7: Four-string kite concept idea	10
Figure 8: Two String kite concept idea.....	11
Figure 9: In-Air winch concept idea.....	12
Figure 10: Kite Tails Stabilization Concept	14
Figure 11: Detailed View of Airplane Stabilizer	14
Figure 12: Kite Rudder Stabilization Concept	15
Figure 13: Double Winch Stabilization Concept	16
Figure 14: Spring response based on displacement of the magnet.....	17
Figure 15: Demonstration Model using three concentric springs	17

Table of Tables

Table 1: Showing how the work load has and will be distributed 9

Table 2: Pugh Matrix used to compare concept ideas 13

ABSTRACT

The purpose of this project is to design a kite based water collector for remote islands that generates power. To generate power, the kite will be tethered to a permanent magnet within a housing that contains an electric coil. As the kite is subjected to a wind load, the kite will pull the magnet through the coil. When the load decreases, a spring or hydraulic will force the magnet back through the coil housing. Electricity is generated each time the magnet slides through the magnetic housing. The kite will also collect water from the moisture in the atmosphere. The kite will condense the moisture which will then travel along the tether of the kite to an aquifer.

ACKNOWLEDGMENTS

Thank you to Jeff Phipps for making himself available through email to answer our questions in regards to this paper and for coming up with the original idea for this project. We would also like to thank Dr. Shih and Dr. Gupta for presenting us with this project and giving the opportunity to execute the desired tasks.

1. Introduction

The idea is to achieve power generation from a water collecting kite in remote island areas. The purpose for this project is to provide affordable power for areas that do not have a major reliable source for power. To harness the energy of the wind without constructing a permanent wind turbine a kite power generator will be used. Conventional wind turbines need a permanent setup and require a high amount of maintenance. Other forms of alternative energy such as solar power can be very costly to initially install and can only generate power when there is direct sunlight. Kite power allows for more maneuverability and less maintenance due to less mechanical parts. Placing in an area like the Greek Islands, where there are constant prevailing winds also allow for kite to be in the air and generate power at almost all times.

The kite will be of relatively simple design and construction, as to make the product inexpensive and economically appealing. The simplicity of the design will warrant very little service and costs resulting in maximum in-service time. This design will also allow the kite to be retracted at times when necessary, thus making it less intrusive to the surrounding environment.

The kite will generate power by oscillating a magnet inside of an electrical coil. To get the kite to oscillate and still sustain flight, combination gearing and/or cam design will let one end of the kite go while pulling on the other end causing a teeter-totter like motion. This will vary the angle of attack of the kite thus varying the lift force and tension on the string. In combination with the spring connected to the magnet pulling it back down, and the changes in the lift force, the magnet will oscillate. There is also an issue of sustaining equilibrium in the roll axis of the kite. To achieve this a tail design could be used or another gearing/cam. This, however is outside of the required project scope.

The power generator consists of a housing that has a top and bottom and a hollow interior. The coil will be situated within the housing, where the magnet will consistently pass through. A spring will be fixed on one end to the housing with the other end of the spring connected to the magnet (Figure 1). As the kite is subjected to a wind load, the magnet, connected to the tether of the kite, will be pulled through the coil housing. As the wind load decreases, the spring acts to restore its natural state by forcing the magnet back through the coil housing. The housing is attached to a swivel port, allowing the housing to spin on its axis depending on the direction of the wind and the flight path of the kite.

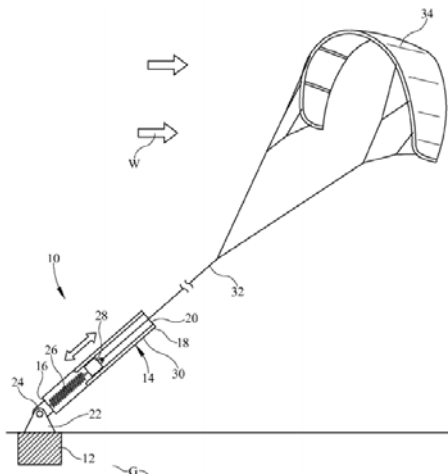

Figure 1. Jeff Phipps Pogo Solenoid Patent [1]

The cycle that the kite will undergo to achieve power generation can be seen in Figure 2. Here the kite will fly in unsteady wind conditions and in a figure-8 like pattern. The figure-8 pattern will be the main source of the oscillation for the magnet, while the springs are meant to assist in the oscillation and keep the magnet bounded inside of the coil. When the magnet racing through the coil, voltage will be generated via faradays law. B refers to the magnetic strength of the magnet, A is the cross sectional area, N is the number of wraps in the coil, and t is the time it takes for the magnet to travel through the coil. It can be inferred that the voltage, thus the power, that will be generated is directly related to the rate at which the magnet travels through the coil. As the spring is stretched, hooks law will force the magnet back through the coil. Here k is the spring constant, and Δx is the displacement of the spring.

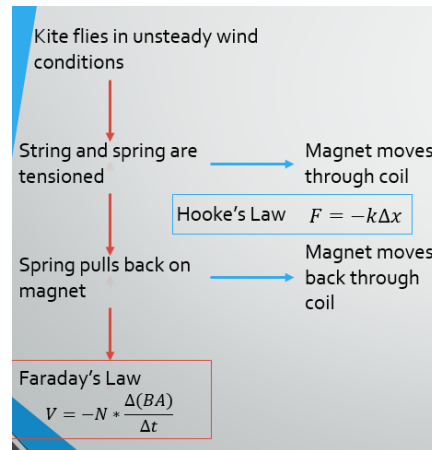

Figure 2. Flow chart of power generation for magnet through coil attached to a spring

2.0 Project Definition

In this section background research, will be presented about various companies and what they have done that is like the design goals that are being pursued. It will be important in future endeavors to have reliable reference material to fall back on to check what will work. In addition to the background research, a need statement will be defined, the constraints will be clearly listed, and the methodology of how the project will be approached will be laid out.

2.1 Need Statement

The need statement for this project is as follows:

Design and build the power generating system of a kite power generator, and scale for a 100kW concept kite.

2.2 Background Research

2.2.1 Kiteship

In regards to harnessing power from the wind via the motion of a kite, it is important to take note of other companies who have successfully built such mechanisms. One in particular is Kiteship[2], a company that utilizes sail-kites on freight commercial ships as an aid to pull the ships in their journey across the ocean. The company also holds the world record for the largest kite to pull a land vehicle and largest vessel pulled by a kite. To put things into perspective, a 13,000-square-foot kite allows for fuel costs to be decreased by 10-20% on a normal-sized commercial vessel. This directly translates to \$400,000 in savings per year. Thus, kite-sails are a more cost-efficient and energy-saving green alternative to transporting traded goods across the world. It can be taken note that the bigger the kite, the more wind energy will be generated and the higher the kite, the stronger the winds. Utilizing this information in further projects will be deemed useful in generating more wind power through the motion of a kite.

2.2.2 Skysails

Skysails[3] is another company that serves as a more efficient and green alternative to utilizing wind power than the conventional sails propulsion systems. The flying towing kites generate 25 times more power than the sails previously used. It works through the control pod which is used to steer the kite in front of the vessel to help pull it in the right direction (Figure 3). The kite and control pod are connected via a towing cable covered by a coat of synthetic fiber that serves as communication for steering between the pod and kite. It is interesting to take note that there is no need for a launching aid such as a balloon filled with helium since the kites are intended to be used in the ocean where there are strong winds. The winds are monitored in direction and velocity to achieve optimal propulsion from the kites.



Figure 3. Skysails used for towing boats so no electricity is used

2.2.3 Strandbeests

Strandbeests[4,5] are giant artistic structures made from PVC piping, wood, and fabric that are self-propelled. Theo Jansen created the first Strandbeest in 1990 and he continues to create them today. Over the years they have evolved into more complex and lifelike creatures. They are self-propelled, using wind power to move around, and have specialized adaptations to help them “survive” on the beach. The Strandbeests have a “spine” that runs down the middle of the structure and acts as a crankshaft for the legs. The legs are designed so that there are always multiple legs supporting the structure at any one time. The more complex Strandbeests (Figure 4) move using wind power and stored up wind energy when necessary. They use sails to initially capture the energy of the wind and use it for movement. Wings are used to power pumps that can pump air into plastic bottles. When these bottles are filled, the air inside can be released and used to move the Strandbeests when there is no wind. The complex Strandbeests also include reflexes to react to certain scenarios. For example, if a Strandbeest detects water, it will turn and go towards high ground or, if it detects high winds indicating an approaching storm, it will stop and anchor itself. Jansen refers to the Strandbeests as animals due to their ability to move on their own and he tours the world showcasing his creations.



Figure 4. Strandbeest creation that will walk across a beach using only wind power

2.2.4 Kitano

Kitano[6] is a concept yacht that uses a kite as the primary means of propulsion with dual water jets used as secondary propulsion during calm winds. Using a kite as propulsion instead of a sail has advantages that include being able to capture more constant wind speeds at higher altitudes and generating more forward force using less surface area. This means that even a light breeze will provide enough force to propel the yacht to planning speed. The position of the kite can be changed which can be used to counter the force of heeling and the yacht can sail without tilting. This makes for a smoother ride and lessens the chance of the passengers experiencing seasickness. Electric winches are used to control the position of the kite. The autopilot controls the winches to compensate for unexpected changes in wind speed and direction. The kite can also be steered manually by changing the tension in the lines connected to the kite. The position of the hauling point of the kite on the yacht can be changed in the longitudinal and transverse directions depending on the direction of the course. The kite will have helium filled bladders to help support the kite during launch and to keep the profile. As of now, it is just a concept however that will most likely change in the future as sustainable energy becomes more prominent.

2.3 Goal Statement/Objectives

There are two end goals to this project. The first goal is to demonstrate that the scaled power generating device will be able to turn on a light bulb. In an ideal world, a kite would be used as the mechanical input, however if that is not possible a hand pulling on the kite string can be used. The main challenge in doing this is to get the kite to oscillate to generate power via a pogo solenoid coil. The second goal of this project is to harness the moisture in the air at altitude and deliver it to an aquifer on the ground. For this aspect of the project, a proof of concept with detailed drawings is all that is needed. There is also a desire to come up with a mechanism that

will launch the kite when the winds are strong enough and gracefully lower the kite when the winds die down.

2.4 Constraints

When designing the power generating subsystem of a kite power generator it is important to know what limitations there are for a specific design. For the project that will be executed the power generation will be optimized for altitudes between 500 and 1500 feet. The kite generator will also be optimized for a specific region, the Islands of Greece. The altitude constraint along with the geographic constraint will allow for the design of a kite that a certain nominal wind speed for that region and altitude. The kite must also deliver AC power to the grid so that it is generating usable electricity. The parts that are used in the assembly of the kite power generator must be off the shelf-products to allow for efficient assembly of the system with no manufacturing of custom parts involved. It is important to operate within these constraints to ensure that the concept designs are on target and will achieve the desired function.

3. Methodology

To meet the goals of the project, working together and scheduling out tasks ahead of time plays an important part and ensures that things get done. Every team member is assigned with a position and tasks to complete based on their strengths in the field in order to complete the project as efficiently as possible.

3.1 HOQ

While the team was still the background research phase of the project, a house of quality (HOQ) was generated to narrow the focus of the project and allow for the more time to be spent on important engineering characteristics and customer requirements. The HOQ can be seen in Figure 5, showing all engineering characteristics and customer requirements. Each category is also scored. The higher scored engineering characteristics and customer requirements are the ones that are more important while the lower scored items are considered to be less important.

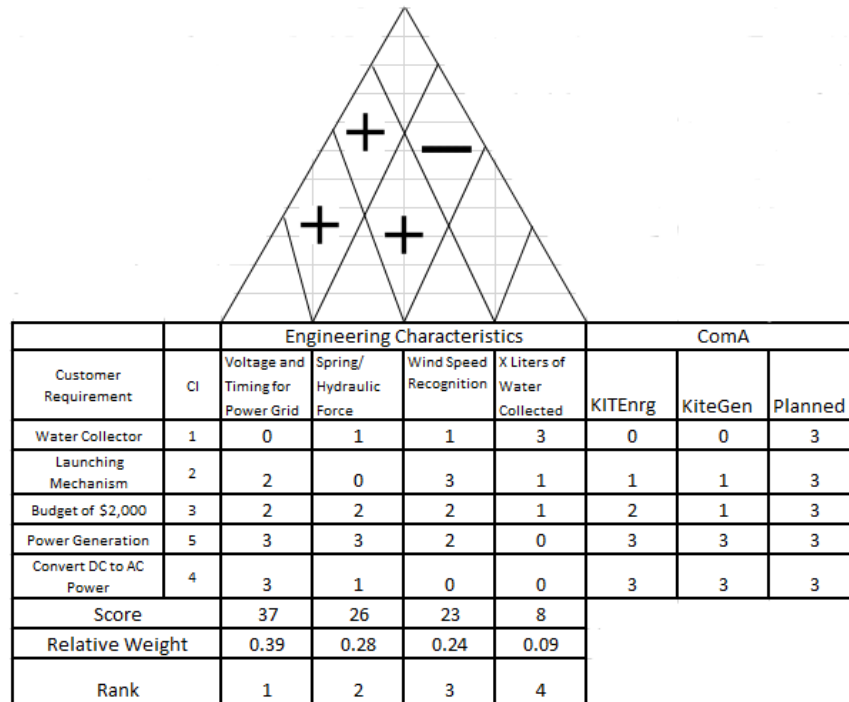

Figure 5. HOQ to show initial customer requirements and engineering characteristics

Through weekly meetings with our sponsor and adviser, the customer requirements/scope are constantly evolving since it is still early on. This means that the HOQ is constantly evolving and new evaluations are done week to week. For this reason, instead of recreating a HOQ every week, and list of customer requirements and goals is kept and those goals are ranked each week. The current list is as follows from most important to least important: Power Generation, Kite Control, Cost, Ease of Deployment, Mobility, and Maintenance. These criteria were used in coming up with good concept ideas.

3.2 Scheduling

Figure 6 shows the schedule for the project is presented in the form of a Gantt chart where it clearly shows the name of each task, the duration of the completion, and the beginning and end date, excluding ME deliverables since they are fixed assignments that will be completed alongside the project.

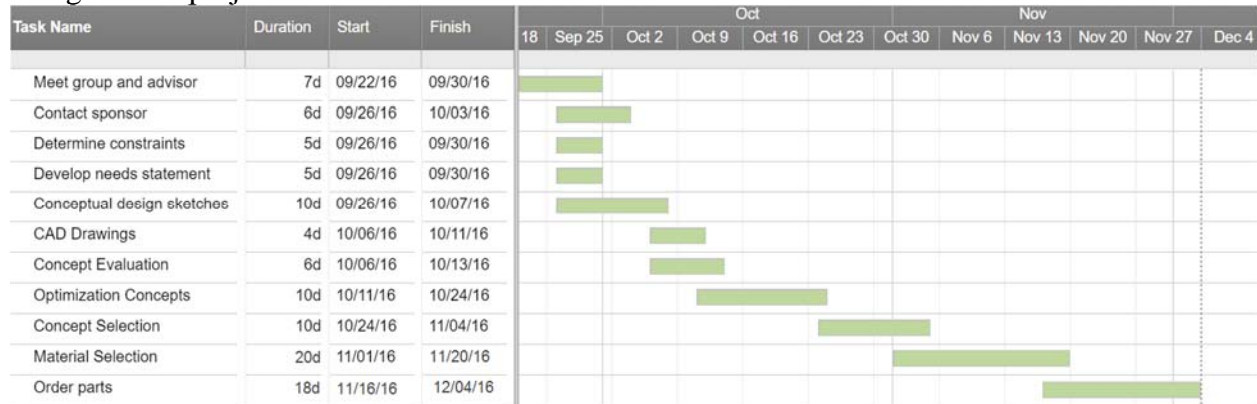

Figure 6. Schedule for the remainder of the semester

In reference to the Gantt chart, the first task of the team was to meet its members and set up a meeting with the advisor. Background research shortly followed on various different companies with a similar a goal statement as the kite-powered generator in order to gain insight on how to proceed with determining the constraints and the needs statement of the project. Then, the team proceeded to develop concept drawings that satisfied all the needs of the project but also worked around the constraints. The three designs were generated using CAD software and compared using a Pugh matrix based on the five main design considerations: maximum power generation, kite control, cost, ease of deployment, and maintenance. These designs were each compared and evaluated in order to choose the most suitable one under the five design considerations.

The next stage, concept optimization, consisted of the analysis of different concepts that could be applied to the final concept in order to permit maximum power generation since that is the main goal. After material selection, the team is currently in the stage of ordering parts in order to build the demonstration model and begin running tests. The team also meets every week with the sponsor and advisor to stay on track with the tasks needed to complete the project. The team actively meets every week to work on tasks together, distribute work evenly, and discuss project details to ensure the team stays on track with the Gantt chart.

3.3 Resource Allocation

Every person on the team holds a specific responsibility and is assigned an individual assignment each time a task needs to be completed in order to complete said task on time. The tasks are divided evenly among the team members as shown in Table1, including ME deliverables.

Table 1. Distribution of workload

Task	Team Member(s) Responsible
Background Research: Kite Power Generation	Denitsa, Zachary
HOQ	Andrew, Matthew, Denitsa, Zachary
Project Planning: Gantt Chart	Andrew, Denitsa
Needs Statement/ Goal Statement	Andrew, Matthew
Code of Conduct	Andrew, Matthew, Denitsa, Zachary
Concept Generation	Andrew, Matthew, Denitsa, Zachary
CAD Concept Drawings	Matthew, Zachary
Concept Evaluation: Pugh Matrix	Andrew, Denitsa, Zachary, Matthew
Concept Optimization	Andrew, Denitsa, Zachary, Matthew
Midterm 1 Report	Andrew, Denitsa, Zachary, Matthew
Kite stabilization design	Matthew, Andrew
Power generation analysis	Denitsa, Zachary
Springs stiffness design	Matthew, Andrew
Material Selection	Andrew, Denitsa, Zachary, Matthew
Order Parts	Andrew, Denitsa, Zachary, Matthew
Final Report	Andrew, Denitsa, Zachary, Matthew

The table excludes tasks such as team meetings, communications with the sponsor and advisor, and any type of correspondence. Andrew Colangelo handles the communication as Team Leader. He holds the responsibility of delegating tasks based on the team's strengths while making sure every member gets their assigned tasks completed in time. He also takes the lead in future planning, organizing, and setting up the weekly meetings with the sponsor as well as the team meetings.

Zachary Ezzo is the team's Lead ME, who manages the mechanical design aspect of the project. He holds the responsibility of being well informed of the design specifications and leading the team through the design process. He presents design options to the team that fall under the project's design considerations and are within the constraints.

Denitsa Kurteva is the team's Financial Advisor, who holds the responsibility of managing the project budget and performing costs analyses on the designs chosen for cost optimization. She holds a record of all credits and debits of the project's account as well as budget adjustments.

Matthew Hedine is the team's Lead CAD Design who is in charge of all computer modeling. He holds the responsibility and computer modeling the concepts generated and delegating design work, as well as generating design drawings.

4. Concept Generation

In the creation of the design concepts, the major considerations taken included maximum power generation, kite control, maneuverability, ease of deployment and maintenance. A pogo solenoid base was used on each concept design to mock the already patented idea from our teams sponsor Jeff Phipps.

4.1 Concept Idea 1

To gain control of the kite and generate the maximum possible power from the wind speeds, it is important to consider the angle of attack and its direct correlation with the frequency of the kite's oscillation. In the first concept design generation, four strings are used and attached to the kite on one end and to the magnet on the other end. To optimize the oscillation of the kite to take account varying wind speeds, mechanical winches are added onto each of the four strings that allow for the user to gain control of the kite's angle of attack. One of the benefits of this design is that the winches are close to the ground which allows for easy user access when in operation.

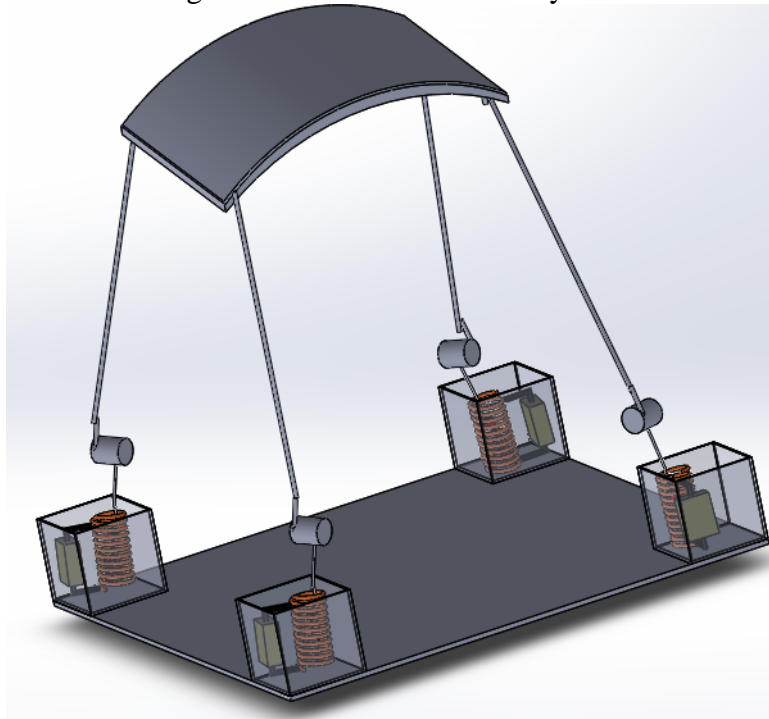

Figure 7. Four-string kite concept idea

In Figure 7 inside the power generation box, the string is attached to the magnet which moves back and forth inside the coil with the kite's oscillation. Thus, the higher the oscillations, the quicker the magnet moves inside the coil and generates power via electromagnetic induction. The AC current that is generated will then go through a rheostat which will convert it into DC. This current will then go through an inverter which will convert the electricity back into AC and allow the electricity to be distributed to the grid. The magnet is attached to a spring that would allow the magnet to oscillate back and forth. As the kite oscillates and pulls the magnet away from the ground, the spring brings it back to keep it inside the area of the coil and can generate a

voltage. The stiffness of the spring will depend on the length of the coil since the magnet must stay inside the coil for power to be generated.

This design is beneficial in that it allows the user to easily gain control of the kite from the winches that are close to the ground. This would allow full control of the oscillation of the kite which in turn would in theory generate the maximum power possible. However, while four strings allow for maximum control of the kite, it is important to consider the energy loss from using multiple strings. The vibrations in the system from the kite's oscillation would be distributed over four strings, thus not providing enough tension in each string to generate maximum power.

4.2 Concept Idea 2

Figure 8 shows the two-string kite design is a condensed version of the four-string kite design. This design relies on two kite tethers attached to either side of the kite and connected to the ground. The advantage of having two less kite tethers is that more tension is created in the remaining two tethers. The lift force due to the wind load is now dispersed to only two tethers rather than four. This allows for a higher spring tension which in effect will cause more oscillation. The weight of the kite will also be much less, allowing the kite to easily remain in the air when wind speeds begin to diminish. Having two tethers on either side of the kite still allows for moderate control of the kite. This design will not allow for full control of the kite as does the four-string kite, however, the kite's angle of attack would still be able to be altered with minimal energy input. Also, with the two-string kite design, the mechanical components will be on the ground making it easy for repair and maintenance when necessary. Containing the mechanical components either in the housing or near the ground helps to avoid the issues caused from the natural elements.



Figure 8. Two String kite concept idea

4.3 Concept Idea 3

Figure 9 the in-air winch design differs significantly from the previous two designs. This design will incorporate only one kite tether attached to the ground to generate power. Utilizing only one tether maximizes the tension resulting in greater oscillation. This design uses a single housing to generate power. This is beneficial in that there is less surface area needed to deploy the kite as well as less hardware that can break down. However, if the housing does break down, the kite will then cease to generate power until the housing is repaired.

The in air winch design, as it states, has the winch in the air near the kite, rather than near the ground or housing. Having the winch connected in the air near the kite creates a focus on the single tether coming down to the housing. This prevents any tangling of tethers as the wind loads fluctuate as well as a smaller of a chance of interference to the surrounding environment.



Figure 9. In-Air winch concept idea

4.4 Selection Matrix

Through the background research and deliberation, the concept ideas were presented as potential ideas to use going forward. In an effort to narrow the focus of the project a single design was chosen using the Pugh Matrix seen in Table 2. The design considerations are different from those found in the HOQ because after meeting with the sponsor of the project, he wanted to change the scope of the project to be more on the power generating device rather than the kite design itself.

Table 2. Pugh Matrix used to compare concept ideas

Criterion	Baseline	Weight	4-String Kite	2-String Kite	In-Air Winch
Power Generation	0	6	0	0	1
Kite Control	0	5	1	0	-1
Ease of Deployment	0	3	-1	1	0
Mobility	0	2	-1	0	1
Maintenance	0	1	-1	1	-1
Cost	0	4	-1	0	1
Sum	0	-	-5	4	6

The decision was made to move forward with concept idea 3 which is the in-air winch design. This decision was partially based on the Pugh Matrix and partially based on discussion with the sponsor and the advisor to the project.

4.5 Kite Stabilization Concepts

Concept idea 3, the in air winch, will be the concept that will be used moving forward. However, a challenge with this concept is the stabilization of the kite. It is thought that this concept will have little yaw control, which is rotation around the vertical axis. Therefore, stabilization will most likely have to be added to the kite in order to increase stabilization and control.

4.5.1 Kite Tails

The first concept involves kite tails for stabilization. Figure 10 below shows the In-air winch concept model with kite tails. The kite tails would be placed on the back of the kite in order to create a drag force. This drag force will stop any unwanted yaw rotation by providing an evenly distributed force on the back of the kite. The tails would be long and thin so as to minimize their weight while maximizing the amount of drag force they can generate. The drag force should be large enough to prevent the yaw rotation yet not enough to simply pull the kite backwards and

make it fall out of control. This concept is the simplest of the 3 and provides the most effective stabilization but it does not provide additional control over the kite.

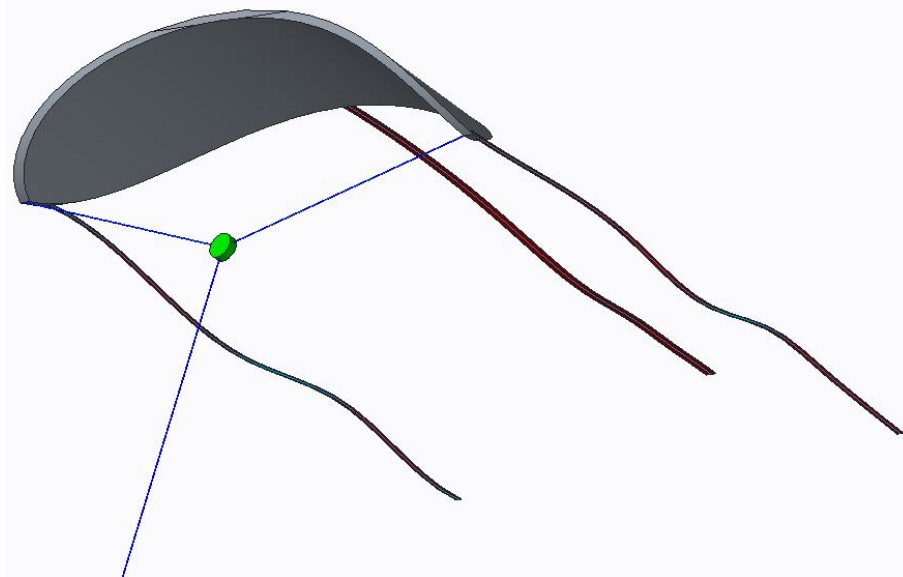

Figure 10: Kite Tails Stabilization Concept

4.5.2 Kite Rudder

The second concept has a single large rudder that hangs from the kite itself. This rudder would act similar to the tail of an airplane. Figure 11 shows a detailed depiction of the tail of an airplane.

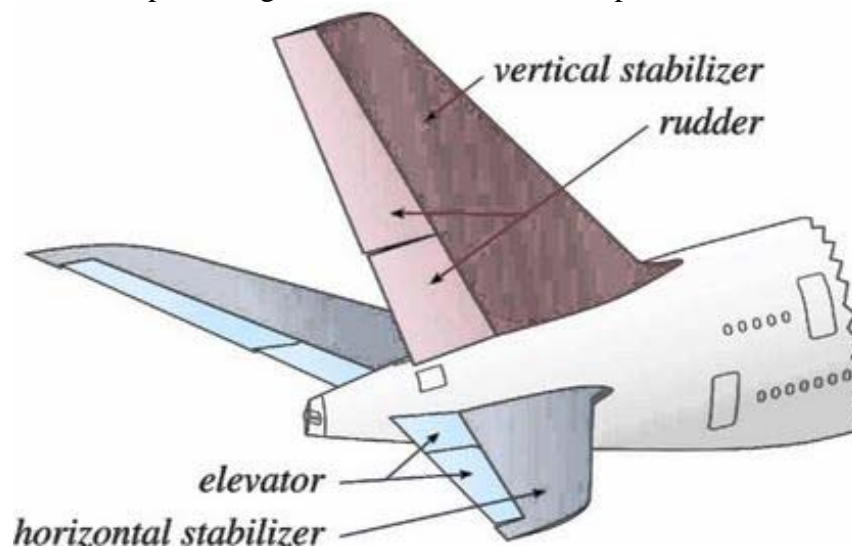

Figure 11. Detailed View of Airplane Stabilizer

As seen in the figure, the tail has a vertical stabilizer that has rudders which provide yaw stability and control. The tail also has a horizontal stabilizer that also has a rudder. This provides longitudinal stability and control. This method of stabilization allows for control of the yaw and pitch of the kite. However, the stabilizer would need to be constantly analyzing the position of the kite and the wind speed and direction in order for it to correctly move the rudders so the kite stays on the correct path. This would require additional components to the system which will make it

more complicated and expensive. There is also little research to show the effectiveness of this method.

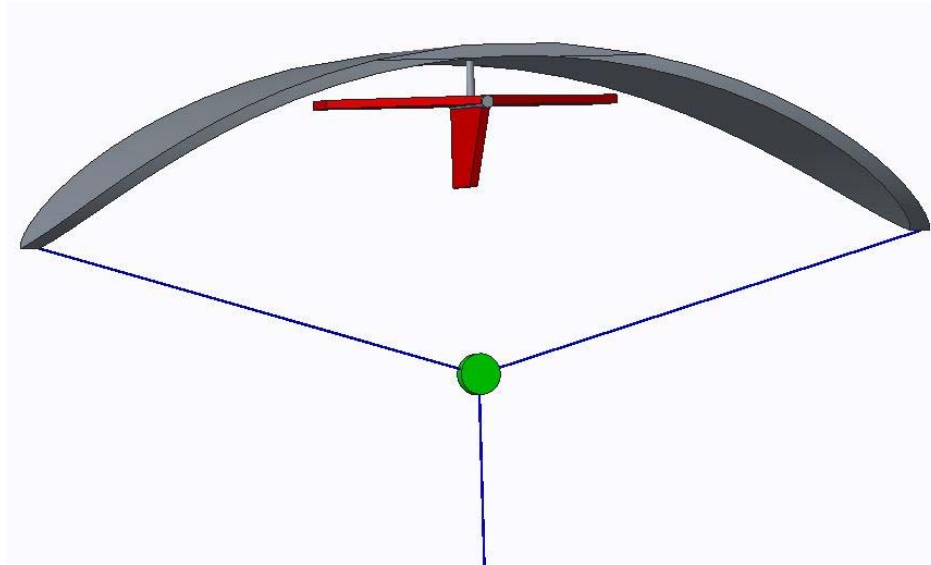

Figure 12. Kite Rudder Stabilization Concept

4.5.3 Double Winch Stabilizer

The third concept adds a second winch to the In-Air Winch conceptual design. The idea behind it is that the first winch will be attached to the strings connected to the sides of the kite. This will allow the winch to change the roll of the kite and make it turn left or right. The second winch will be attached to the string connected to the front and back of the kite. This will allow the winch to control the pitch of the kite and make it go up or down. It can also change the amount of drag the kite is generating and increase the stability if needed. This method would allow for the most kite control of the three concepts. As for stability, it would require additional components to measure the position of the kite and the wind speed and direction, much like the second concept. This adds additional complications in terms of maintenance and repairs that will be required as well as the overall complexity of the system. It would also increase the cost.

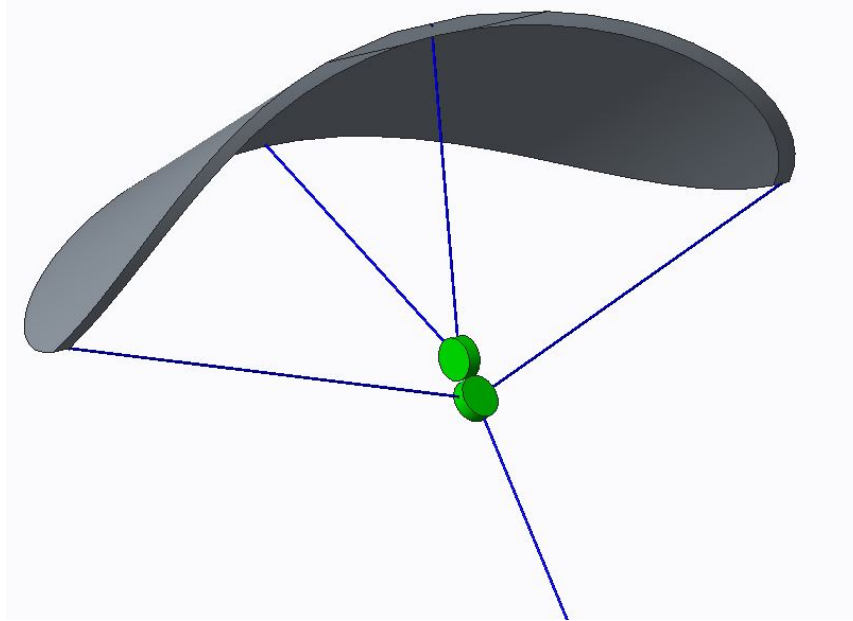

Figure 13. Double Winch Stabilization Concept

4.5.4 Evaluation

The scope of the project was narrowed down in order to focus on power generation but maximizing power involves the control and stabilization of the kite. The kite will fly in a figure 8 pattern so as to create oscillation of the magnet. The stabilization ideas are strictly concepts to try and figure out viable ways to control and stabilize the kite in the scaled up concept model. The stabilization conceptual designs were all based on the In-Air winch design because that will be the design used moving forward.

4.6 Demonstration Model

The design for the demonstration model is a simplistic design as compared to the overall design considerations. The demonstration will focus on the power generation aspect, therefore a kite is not necessary. For this design, the demonstration entails a force on a string that will pull the magnet through the solenoid as well as return it to the previous position. The mechanical input could include either weights attached to pulleys being dropped, or a string with a handle with which a person would exert a force on the string pulling on the magnet. The demonstration model will utilize concentric compression springs to create a force that increases with a step response when the magnet is displaced and contacts another spring. The springs are in parallel, therefore allowing the overall force to increase as the magnet is displaced. The forces that will be exerted by the springs can be seen in Figure 14.

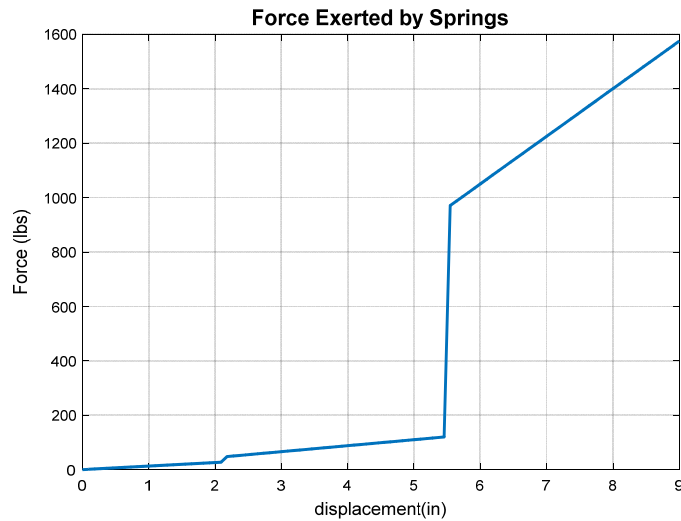

Figure 14. Spring response based on displacement of the magnet

Figure 15 provides a nice visual on how the demonstration model will be laid out. A third spring will be used for the demonstration to act as a safety mechanism. This spring will have a very high stiffness coefficient to prevent any damage to the model under high forces. With this spring, any reasonable force applied to this model will not fully compress any of the springs used.

The magnet that will be used for this demonstration is a neodymium circular disk magnet. A string will be fed through the hole in the middle of the magnet and will be attached to the bottom side to allow the magnet to be pulled up when a force is applied. The magnet has a strength of 1.32 Teslas, which is needed to achieve the desired voltage output.

Per the sponsor's request, the demonstration model is to be of a very simple design to demonstrate the power generation due to oscillation of a magnet through a solenoid. The model will be used to power a battery which in turn will be used to power a LED light. A battery is used for this model because a consistent voltage is not expected throughout the entire demonstration. Therefore, this allows the model to fully charge the battery before being used to light the LED.

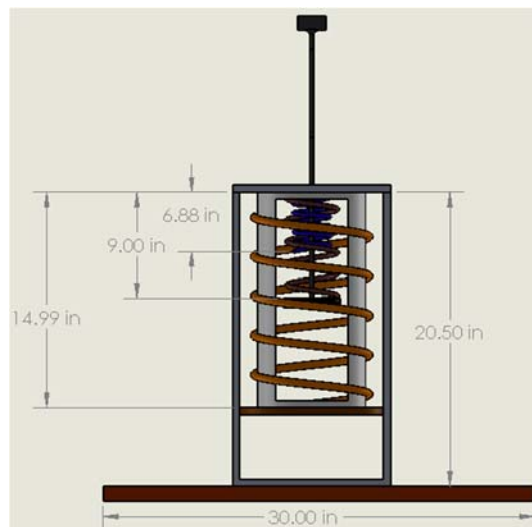

Figure 15. Demonstration Model using three concentric springs

5. Conclusion

Through background research and deliberation a final demonstration model was selected along with the spring set that will be a major part of the system. The demonstration model will consist of three concentric springs. The first and second spring will work in combination to provide resistance, while the third spring is meant to be the safety mechanism. The safety mechanism is there so that no plastic deformation is done to the springs to extend the life of the mechanism. The magnet must travel at 50 wraps/second which will be achieved. Because there will not be a steady, uninterrupted supply of power, the demonstration model will charge batteries that will then be used to power a 40W light bulb.

Progress was also made on the scaled concept kite. Kite tails were added to the concept model that was selected to provide drag and stability to the kite. In the spring semester, a call to Theo Jansen will be made to try and come up with a mechanical mechanism that will force the kite to fly in a figure-8 like pattern. Before that call can take place, calculations will need to be done to determine the speed at which the kite will need to maneuver, and the width of the pattern.

Next semester the demonstration model will be assembled and tested. The scaled kite design will also be finalized with the assistance of Theo Jansen, and if there is enough time, the idea of water collection will be tackled.

References

- [1] Phipps, Jeff. "Patft » Page 1 of 1." *Patft » Page 1 of 1*. Uspto, 20 Jan. 2014. Web. 30 Sept. 2016.
- [2] Doan, Abigail. "POWER YOUR BOAT WITH KITES: Wind Power by KiteShip." *Inhabitat Green Design Innovation Architecture Green Building*. Inhabitat, 23 Oct. 2007. Web. 30 Sept. 2016.
- [3] "POWERFUL - UNLIMITED - FREE." *SkySails GmbH - SkySails Propulsion for Cargo Ships*. N.p., n.d. Web. 30 Sept. 2016.
- [4] "Mini Beasts | Books Beast Photos Events Theo Jansen Contact." *STRANDBEEST*. N.p., n.d. Web. 30 Sept. 2016.
- [5] "Strandbeest: The Dream Machines of Theo Jansen." *Exploratorium Blog*. N.p., 16 Sept. 2016. Web. 30 Sept. 2016.
- [6] Yacht, Kite Sailing. *KITANO* (n.d.): n. pag. *Princess of Style*. Kitano. Web.
- [7] "U.S. Energy Information Administration - EIA - Independent Statistics and Analysis." *EIA Projects 48% Increase in World Energy Consumption by 2040*. N.p., n.d. Web. 21 Oct. 2016.
- [8] "Fresh Water Resources - Greece - Climate Adaptation." *Fresh Water Resources - Greece - Climate Adaptation*. N.p., n.d. Web. 21 Oct. 2016.
- [9] "Disadvantages Of Solar Energy - Conserve Energy Future." *ConserveEnergyFuture*. N.p., 17 Aug. 2015. Web. 21 Oct. 2016.
- [10] Windfinder.com. "Windfinder.com - Wind Forecast Map Greece." *Windfinder.com*. N.p., n.d. Web. 21 Oct. 2016.
- [11] "Key Points." *Highaltitude Wind Technology Innovative Renewable Energy Wind Energy Kitenergy*. N.p., 17 Dec. 2014. Web. 21 Oct. 2016.
- [12] "High-altitude Wind Energy from Kites!" *Saul Griffith:*. N.p., n.d. Web. 21 Oct. 2016.